

Chapter V - Finishing Techniques

Cemented carbide parts can be finished to the desired shape, size, flatness, and surface finish by diamond wheel grinding or by diamond lapping and polishing. In addition, EDM (electrical discharge machining) has risen in prominence and popularity among carbide fabricators. Both techniques are covered here in detail.

Fundamentals of Grinding

Diamond wheel grinding, in an overly simplified way, can be described as removing undesirable portions of material from a part by subjecting it to repeated overlapping contact with a rotating diamond wheel (Figure V-1). During the grinding process, the rotating diamond wheel is brought down on the work piece so that the tips of the exposed diamond particles barely touch the surface to be ground (Figure V-2). At this starting point, the work piece is subjected to either a reciprocating or a rotating motion, and the wheel is dropped further by an amount equal to the depth of cut (D_c). The process is repeated n times until the desired amount of material equal to $n \times D_c$ is removed.

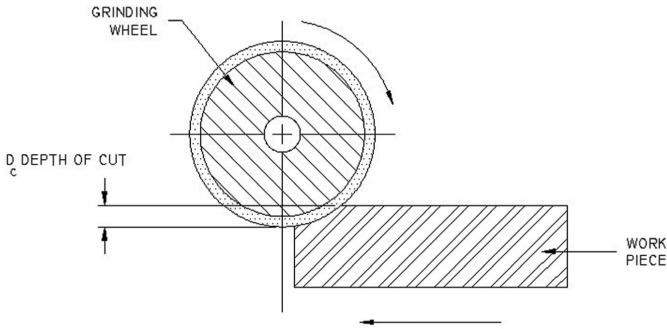

Figure V-1. The grinding process. The depth of cut is exaggerated for illustration purposes.

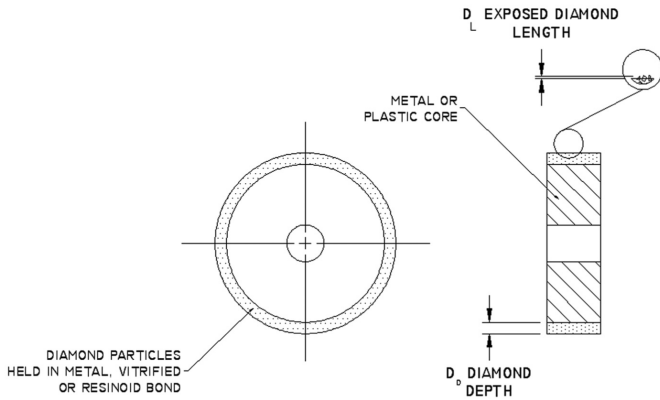

Figure V-2. A typical diamond wheel contains uniform but randomly distributed diamond particles.

Grinding Factors

It is apparent from the above figures that if the wheel is fed into the work piece deeper than the exposed diamond length (i.e., if $DC > DL$), damage to either the grinding wheel or the work piece will result. In cases where $DC = DL$, a considerable amount of heat is going to be generated due to the rubbing that occurs between the work piece and the wheel bonding material. Coolant used for removing excessive heat will also not be very effective due to the collapse of annular space between the wheel and work piece. Therefore, the ideal situation is when $DC = 1/2 DL$ and is maintained throughout the grinding range. In almost all types of grinding (reciprocating, cylindrical, centerless, etc.), the feed rate is maintained at the depth of cut per pass. The greater the DL , the greater the DC can be, resulting in a higher rate of material removal. The limiting factor, of course, comes from the fact that to increase the DL , coarser grit diamond particles must be used, which influences the surface finish of the part.

Surface Finishes

An "as-sintered" piece of cemented carbide has a surface finish of approximately 50 to 60 microinches and may have surface irregularities several thousandths of an inch deep, as a result of the sintering operation. This "as-sintered" surface can be improved and the part brought to correct size by proper grinding techniques and the appropriate diamond wheel.

The following table indicates the finishes that can be obtained with good grinding practices and the appropriate grit size of the diamond wheel. For lower microinch readings, diamond lapping or polishing of the part will produce the desired result.

Grit Size	Particle Size		Expected Surface Finish (R _A)
	Micron	Inch	
80	267	0.0105	24-36
150	122	0.0048	14-16
180	86	0.0034	12-14
220	66	0.0026	10-12
320	32	0.0012	8
400	23	0.0009	7-8
600	14	0.0006	2-4
1200	3	0.0001	1-2

Grinding Cautions

It is essential to avoid thermal shock caused by sudden changes in temperature, such as loss of coolant flow. Thermal shock will produce grinding cracks, which can appear as crazing and large cracks. Crazing is a pattern of hairline checks that appear on the surface of the part caused by a rapid rise in the surface temperature of the carbide relative to the cooler interior. These thin cracks can be difficult to detect and may only be visible under magnification or by dye penetrant crack detection methods. Thermal shock can also produce large, visible cracks. These will also result from an extreme temperature gradient from the interior to the surface, particularly in a localized area. Avoid excess pressure on a small contact area even when using the proper type of grinding wheel to prevent this condition.

Grinding Recommendations

Wet grinding is strongly recommended to minimize overheating and cracks. Grinding fluids specially developed for carbide grinding, are commercially available and should be used. These fluids do not contain leaching chemicals that will leach or degrade the carbide structure (as mentioned in Chapter III) yet they provide adequate heat dissipation. The coolant should flow liberally onto the wheel and cover the entire carbide surface. Interrupted or insufficient coolant flow will produce alternate heating and quenching of the carbide surface and cause the carbide to crack because of these temperature changes. If a machine is not suited for a continuous flow of coolant, a mist spray should be used to keep the wheel wet and clean.

The following guidelines are presented to help avoid grinding cracks and crazing:

1. Never let coolant flow be disrupted.
2. Avoid dry grinding unless the operator is extremely skillful and can quickly detect heat buildup.
3. Generally, maintain a feed rate equal to the depth of cut per pass. Avoid an in-feed per pass over 0.0003" on low binder, hard carbide grades, and over 0.0010" for higher binder carbide grades.
4. Avoid using hard-bond diamond grinding wheels, such as vitrified and metal-bonded diamond wheels. Resinoid-bonded diamond grinding wheels are recommended when dimensional accuracy, flatness, and surface finish are important.
5. Dress the grinding wheel frequently to avoid a "loaded" wheel, particularly when grinding steel and carbide in the same pass. If the steel is a blue color from the heat of grinding, a crack will probably be found in the carbide. However, the crack may not reveal itself until the assembly is in use.

Electrical Discharge Machining of Cemented Carbide

What Is It?

EDM or, electrical discharge machining, is the process by which a part is machined using the erosive properties of electrical discharges. Most people think of EDMing as a relatively recent discovery, when in fact it dates back to 1770 when an English scientist named Priestly first discovered the corrosive effect of electrical discharges. However, it was not until 1943 that two Russian scientist/brothers named Lazarenko developed the idea of exploiting the destructive effect of electrical discharges and developed a controlled process to machine electrically conductive materials.

The Lazarenko brothers perfected the EDM process. Simply put, it is a succession of electrical discharges that take place between two conductors that are separated by a non-conducting liquid called a dielectric. Today, this process still bears their name, the "Lazarenko Circuit."

EDM today has two basic types: wire and probe (die sinker). Wire EDM is used primarily for shapes that are cut through a selected part or assembly. A hole must first be drilled into the workpiece and then a wire is fed through the hole to complete the machining. Probe EDMs are used for complex geometries where the EDM machine uses a machined graphite, copper tungsten or copper graphite electrode to erode the desired shape into the part or assembly. Probe EDM does not require a pre-drilled hole in the part.

How It Works

During the EDM process, a series of non-stationary, timed electrical pulses remove material from the workpiece. The electrode, workpiece, and the dielectric are all held by the machine tool. A power supply controls the timing and intensity of the electrical discharges and the movement of the electrode in relation to the workpiece.

An electrical discharge is initiated at the spot where the electric field is the strongest. Under the effect of this field, electrons and positive free ions are accelerated to high velocities and rapidly form a channel that conducts electricity. At this point, current will flow and a spark will form between the electrode and the workpiece. This causes a great number of collisions between the particles. During this process a bubble of gas develops and its pressure rises quickly and steadily until a plasma zone is formed. This plasma zone can reach temperatures in the range of 8,000 to 12,000 °C. due to the large number of particle collisions. This in turn causes instantaneous local melting of a certain amount of the material at the surface of the two conductors. When the current is turned off, the sudden reduction in temperature causes the bubble to implode, which projects the melted material away from the workpiece. This leaves a tiny crater in the eroded material. The dislodged particle then resolidifies into small spheres and is removed by the dielectric.

Designing Carbide Parts With EDM In Mind

EDM, in past years, has been used to produce parts that were difficult to make by other machining methods. **Today, more parts are being designed to take advantage of the EDM process.** More and more design/manufacturing teams are using it as their first choice to manufacture parts.

EDMing should be considered when the part being designed has very thin walls, has small internal radii, has high depth to diameter ratios, or are very small and hard to hold while machining. It also should be considered if the workpiece material is hard, tough, burrs easily or needs to be heat-treated. This makes it especially well suited for machining cemented carbide parts.

As noted in Chapter 1, cobalt is used as a binder in tungsten carbide to hold the particles together when sintered. The amount of cobalt added determines the hardness and toughness of the carbide. The electrical conductivity of cobalt exceeds that of tungsten, so EDM erodes the cobalt binder in tungsten carbide. The carbide granules fall out of the compound during cutting, so the energy applied during the cutting determines the depth of binder that is removed.

When cutting carbide on certain wire EDM machines, the initial cut can cause surface micro-cracks. To eliminate them, skim cuts are used. Skim cutting produces finer finishes because less energy is applied to the wire, thereby creating smaller sparks and thus smaller cavities. **However, it is advisable to alert the carbide supplier that this part is intended to be cut by wire EDM. This is done because some suppliers adjust the formulation of the grade to provide maximum resistance to cracking during the EDM process.**

Some older wire EDM machines used capacitors. Since these machines applied more energy into the cut, there was a greater danger for surface micro-cracking. Later, DC power supply machines without capacitors were introduced. This helped to produce less surface damage when cutting carbide.

Today, many machines come equipped with AC power supplies. These machines are especially beneficial when cutting carbides because they produce smaller heat-affected zones and cause less cobalt depletion than other machines.

To eliminate any danger from micro-cracking, and to produce the best surface edge, it is a good practice to use sufficient skim cuts when EDMing carbide parts. Because EDM does not involve contact with the workpiece, it is possible to design shapes in carbide that would break during production when using conventional machining practices, such as grinding. Parts that cannot take this type of stress can be machined effectively with EDM.

Sometimes it is difficult to machine a part that has thin walls. EDM is ideal for this sort of part because the process does not involve force, contact or deformation. A wire EDM can be used on parts with wall thicknesses as thin as 0.005 inch. A probe EDM can produce walls as thin as 0.002 inches. This makes EDM a good choice when designing small surgical tools from tungsten carbide.

Another consideration for use of EDM is when the part being designed has a high ratio of cavity depth to width, like slots or ribs. Since there is no force between the tool and the workpiece, long electrodes can be used to make very intricate ribs. Wire and probe EDMs are excellent for jet engine blade designs.

Use probe EDM when your design calls for difficult recessed cuts. Conventional cutting tools cannot reach these cutting areas to apply the necessary force.

Hardness of the carbide grade is of no concern when considering EDM. Because the EDM process vaporizes material, instead of cutting it, so the hardness need not be a factor for consideration.

Cutting Speed

Cutting speed is rated by the square inches of material that is cut in one hour. It can vary according to the conductivity and the melting properties of materials. For example, aluminum, a good electrical conductor with a low melting temperature, cuts much faster than steel.

On the other hand, cemented carbide, a poorer conductor, cuts much slower than steel. It is the binder, usually cobalt, that is melted away. Different carbide grades EDM at different speeds because of carbide grain size and the binder amount and type.

EDM Limitations

Maximum workpiece dimensions for wire EDM are approximately as follows:

Y axis = 59 inches

Z axis = 24 inches

X axis = no limit

For probe EDM:

Y axis = 59 inches

Z axis = 17 inches

X axis = 98 inches

Maximum taper angle for wire EDM is + or - 45 degrees

Maximum angle/height combination is 30 degrees at 16 inches high

Accuracy of wire EDM is about 0.00002 inches

Probe EDM is + or - 0.0001 inch

Surface finish is about 4 microinch for wire EDM on a finish pass and 24 microinch finish with a roughing pass.